

Ether
ES
Sound



EtherSound product range

**Simple and cost-effective audio distribution
over standard Ethernet with extremely low latency**

EtherSound allows to easily and economically create audio networks with extremely low latency using standard Ethernet IEEE 802.3x compliant cabling and components. Digigram's EtherSound devices exchange up to 64 channels of 24-bit digital audio at 48 kHz in each direction, plus control and monitoring information, via a single Ethernet cable with only 125 microseconds latency.

Our EtherSound range of products caters to the needs of a broad variety of audio applications: installed sound, touring, background music and paging, broadcast, and logging.

The ability to use EtherSound devices almost anywhere in the audio system breaks through the limitations of analog audio or AES/EBU installation schemes. They eliminate the need to bring all of the audio to a central switching or routing location, reduce cable, cable run, and installation expenses, and greatly simplify system reconfiguration.

Easy to install

Point-to-point connections are replaced by architectures that are easier to design and install: daisy chain, star, a combination of both, and also the fault-tolerant ring using ES-100 compatible devices. The set-up of a dedicated EtherSound network is as simple as plugging an Ethernet cable into a socket and does not require specific IT skills. An EtherSound system may also run within a VLAN (Virtual Local Area Network) as part of an existing corporate network.

Thanks to the inherent routing capabilities of computer networks, input and output allocations may be easily

updated without physical changes to the system's topology. Configuration tasks can be accomplished remotely via straightforward configuration software, or locally on the devices by using built-in rotary switches.

The properties of Ethernet cables (small diameter, no audible electromagnetic interference, etc.) allow for audio systems in areas where a traditional installation is difficult or impossible, as it is frequently the case in retrofit projects. A single Ethernet CAT5 cable can replace a vast number of traditional cables, patch panels, routing matrixes, or other switching devices.

Cost savings at every stage

With a drastic reduction in design, installation, and configuration time, EtherSound is a simple way to complete complex audio installations at an affordable price. The use of standard Ethernet components considerably lowers the material (cheaper cables, reduced number of cables, smaller cable run, less routing hardware) and labor costs. Remote system reconfiguration and diagnostic frees staff from time-consuming site visits. All of these advantages contribute to reduce the total cost of ownership (TCO).

EtherSound product range

Installation

Installing an EtherSound network is very easy.



links might be used to increase this distance to two kilometres (1.24 miles).

EtherSound helps to maximize the cost-effectiveness of the installation by offering the possibility to combine star and daisy chain architectures.



1. Connect the EtherSound devices using standard CAT5 cables and, if appropriate, Ethernet switches. The maximum distance between two devices is 100 meters or 328 feet (Ethernet standard). Intermediate switches or fiber optic

2. Connect the audio sources and destinations to the EtherSound devices.

3. Configure the system using the EScontrol management software via a straight forward routing matrix. All channels are routed independently. Once set-up is complete, the EtherSound network can distribute audio

without an external PC. Some devices offer rotary switches for local channel assignment without the help of a computer.

You're done. The EtherSound system is now ready to distribute high-quality audio!

Ether ES Sound

Low Latency

Minimal latency was one of the key design requirements for EtherSound. No other technology offers such low latency with this many channels and at such a high quality. EtherSound meets the requirements of even the most demanding applications like studio, live sound, and broadcast.

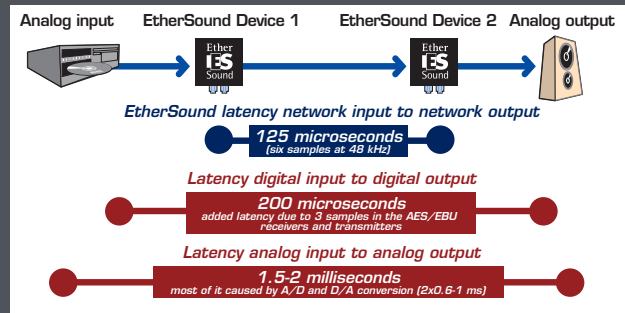

The point-to-point transmission time between a network input and a network output is six samples (125 microseconds at 48 kHz). Each slave module in a daisy-chain only adds 1.4 microseconds to this time. Latency is independent of the number of channels transmitted.

Furthermore, EtherSound is fully deterministic, making it possible to calculate the exact delay between any two devices in an EtherSound network.

Control and monitoring data on the same cable

By transporting control and monitoring data signals on the same cable as the digital audio, EtherSound eliminates the need for separate cables for the control and monitoring of equipment such as amplifiers, lighting, keyboards, automation, etc. GPIO and RS232 ports on Digigram's devices can be managed by a remote computer.

Interoperability

Digigram's products are fully compliant with the EtherSound standard and can therefore interact with products of other pro audio manufacturers that have adopted the same standard. Digigram's products can team up with EtherSound enabled mixing consoles, loudspeakers, amplifiers, DSP devices, loudspeaker controllers, control software, and other equipment to create a comprehensive solution. An up-to-date list of EtherSound compliant products is available at www.ethersound.com.

Example 1: Installed live sound

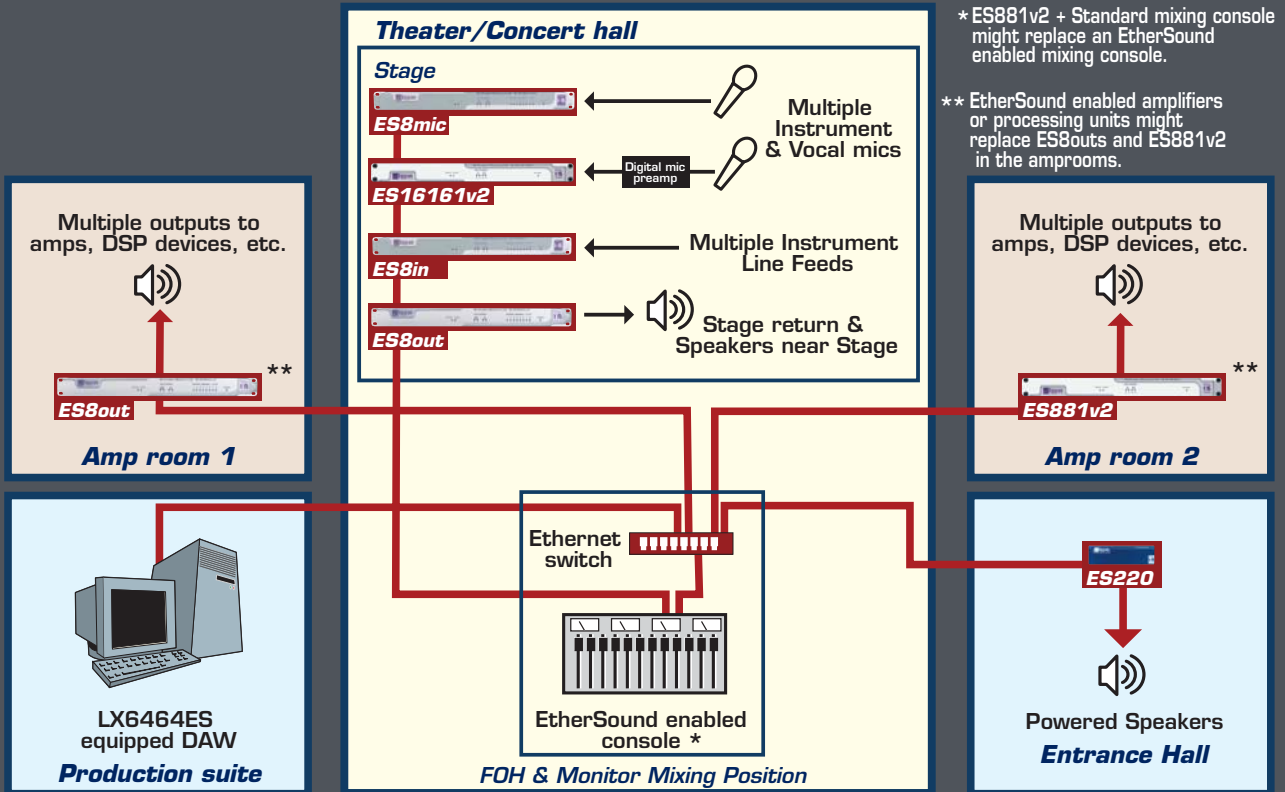

Example 2: Background music and paging system in a multi-building hotel resort

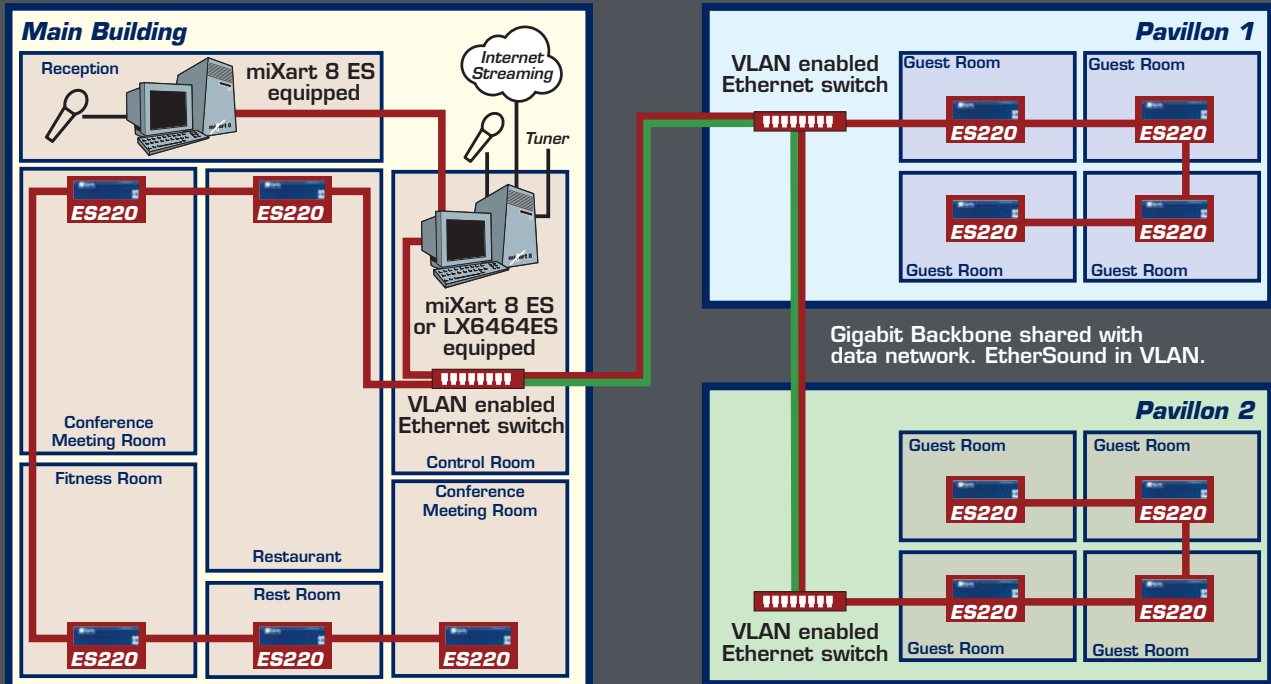

EtherSound product range

Specifications

EtherSound inputs and outputs overview.

	ES-100	ANALOG		DIGITAL AES/EBU	
		Line/Mic mono inputs	Mono outputs	Mono inputs	Mono outputs
ES220/ES220-L		2/-*	2*	-	-
ES8in		8/-	-	-	-
ES8mic/ES8micCL		8/8**	-	-	-
ES8out		-/-	8	-	-
miXart 8 ES		8/4**	8	-	-
ES881v2	•	-	-	8	8
ES1241v2	•	-	-	4	12
ES16161v2	•	-	-	16	16
LX6464ES	•	Linear sound card with 64/64 EtherSound I/Os, full duplex			

* ES220: inputs AND outputs; ES220-L: inputs OR outputs

** Switchable line/mic inputs with phantom power

Devices with inputs and outputs



**EtherSound
ES220/ES220-L**



**EtherSound
ES881v2, ES1241v2, ES16161v2**

Configuration	ES220/ES220-L		ES881v2, ES1241v2, ES16161v2	
Size	1 U 1/3 19" rack: 42 x 146.5 x 210 mm optional 19" rack mount bracket for up to three units		1U 19" rack : 43.9 x 482.6 x 297.1 mm	
Local audio channel selection	Manually by internal rotary switches		-	
Inputs/Outputs				
Audio	2 balanced analog mono line inputs, 2 servo-balanced analog mono line outputs ES220: inputs AND outputs ES220-L: inputs OR outputs (jumper selectable)		Digital AES/EBU inputs and outputs. All inputs with Sample Rate Converter, 1:3 to 3:1, up to 96 kHz. ES881v2: 4 stereo inputs, 4 stereo outputs ES1241v2: 2 stereo inputs, 6 stereo outputs ES16161v2: 8 stereo inputs, 8 stereo outputs	
Input/output impedance	22.2 kΩ / <100 Ω		110 Ω	
Maximum input level	+22 dBu or +10 dBu (jumper selectable)		-	
Maximum output level	+22 dBu (software adjustable)		-	
Analog output gain	from -72 dBu to 0 dB (software adjustable)		-	
Connectivity				
Analog/digital audio	15-pin D-Sub		ES881v2 and ES1241v2: XLR3 ES16161v2: 25-pin D-Sub	
EtherSound	2 EtherCon female RJ45 compatible (connections "IN"/"OUT")		2 EtherCon female RJ45 compatible (connections "IN"/"OUT") 1 Ethernet female RJ45 compatible for PC connection	
Clock	-		2 BNC for Word Clock In and Out	
GPIO and serial interface	4 inputs and 4 outputs on 15-pin D-Sub		4 optocoupled inputs and 4 relay outputs on 8-point terminal blocks 1 RS232 on DB9	
Audio specifications				
Sampling frequency	48 kHz or 44.1 kHz (Using internal clock: 48 kHz only)		48 kHz or 44.1 kHz (Using internal clock: 48 kHz only)	
A/D and D/A converter resolution	24 bits		-	
Frequency response at 48 kHz	20 Hz – 20 kHz: ± 0.2 dB		-	
Dynamic range –60 dBfs with Fs=48 kHz (20 Hz/20 kHz, unweighted)	>102 dB		-	
Distortion and noise (THD+N) at 1 kHz (–1 dBfs with Fs=48 kHz)	<–95 dB (0.0018%)		-	
Phase difference between channels: 20 Hz/20 kHz	0.5°/2°		-	
Crosstalk (–1 dBfs with Fs=48 kHz): at 1 kHz	Inputs:	Outputs:	-	
at 15 kHz	<–116 dB	<–120 dB	-	
	<–92 dB	<–105 dB	-	
Synchronization	Network (44.1 or 48kHz), internal (48kHz)		Network (44.1 or 48kHz), internal (48kHz), Word Clock or AES IN 1 (44.1 or 48kHz)	

Input devices



	EtherSound ES8in	EtherSound ES8mic/ES8micCL
Configuration		
Size	1U 19" rack: 43.9 x 482.6 x 297.1 mm	1U 19" rack: 43.9 x 482.6 x 297.1 mm *
Local audio channel selection	Manually by rotary switches	Manually by rotary switches
Inputs/ Outputs		
Analog mono inputs	8 mono balanced line inputs	8 mono balanced line/mic inputs with switchable 48 V phantom power
Impedance	22.2 kΩ	22.2 kΩ
Maximum level	+22 dBu or +10 dBu with internal jumper	line +22 dBu, mic: +10 dBu, software selectable
Programmable mic gain		0 to 66 dB in 0.5 dB steps
Connectivity		
Analog audio	8 female XLR3 or 24-point terminal block	8 female XLR3 or 24-point terminal block
EtherSound	2 EtherCon female RJ45 compatible (connections "IN"/"OUT")	2 EtherCon female RJ45 compatible (connections "IN"/"OUT")
GPIO	4 optocoupled inputs and 4 relay outputs on 8-point terminal blocks	4 optocoupled inputs and 4 relay outputs on 8-point terminal blocks
Serial port	1 RS232 on DB9	1 RS232 on DB9
Audio specifications		
Sampling frequency	48 kHz or 44.1 kHz	48 kHz or 44.1 kHz
A/D and D/A converter resolution	24 bits	24 bits
Frequency response at 48 kHz	20 Hz – 20 kHz: ± 0.2 dB	20 Hz – 20 kHz: ± 0.2 dB
E.I.N. A/D-D/A at 48kHz, G=36 dB		<-122 dBu (without phantom power) <-116 dBu (with 48 V phantom power), G=36 dB
Dynamic range –60 dBfs with Fs=48 kHz (20 Hz/20 kHz, unweighted)	>102 dB	>96 dB at G=36 dB
Distortion and noise (THD+N) at 1 kHz (-1 dBfs with Fs=48 kHz)	<-94 dB (0.002%)	<-92 dB (0.0025%)
Phase difference between channels: 20 Hz/20 kHz	0.5°/2°	0.5°/2°
Crosstalk:		
at 1 kHz	<-115 dB	<-120 dB
at 15 kHz	<-110 dB	<-102 dB
(-1 dBfs with Fs=48 kHz)		at G=36 dB
EtherSound ES8micCL only		
Maximum input level/impedance		+10 dBu/2kΩ
Programmable noise-gate threshold		-52 dB, -42 dB, -32 dB
Programmable compressor/limiter threshold		From -26 dB to 0 dB
Programmable compressor ratio		1, 1.5, 1.8, 2, 3, 4
Programmable compressor/limiter gain		From 0 to 16 dB
Limiter ratio		15:1
Compressor/limiter release time		150 ms

*Also available in North America: the ES8micWM for mounting in commonly used 16" x 14" x 3" wall enclosures which comply with US and Canadian Electrical and construction low voltage practices

Output devices



EtherSound ES8out

Configuration	
Size	1U 19" rack: 43.9 x 482.6 x 297.1 mm
Local audio channel selection	Manually by rotary switches
Outputs	
Analog mono outputs	8 mono servo-balanced line outputs
Impedance	<100 Ω
Maximum level	+22 dBu, software adjustable
Analog output gain	From -72 to 0 dB, software adjustable in 0.5 dB steps
Connectivity	
Analog audio	8 male XLR3 or 24-point terminal block
EtherSound	2 EtherCon female RJ45 compatible (connections "IN"/"OUT")
GPIO	4 optocoupled inputs and 4 relay outputs on 8-point terminal blocks
Serial port	1 RS232 on DB9
Audio specifications	
Sampling frequency	48 kHz or 44.1 kHz
A/D and D/A converter resolution	24 bits
Frequency response at 48 kHz	20 Hz – 20 kHz: ± 0.2 dB
Dynamic range –60 dBfs with Fs=48 kHz (20 Hz/20 kHz, unweighted)	>104 dB
Distortion and noise (THD+N) at 1 kHz (-1 dBfs with Fs=48 kHz)	<-93 dB (0.002%)
Phase difference between channels: 20 Hz/20 kHz	0.5°/2°
Crosstalk:	
at 1 kHz (-1 dBfs with Fs=48 kHz)	<-115 dB
at 15 kHz (-1 dBfs with Fs=48 kHz)	<-110 dB

EtherSound product range

PCI sound cards



miXart 8 ES*

LX6464ES



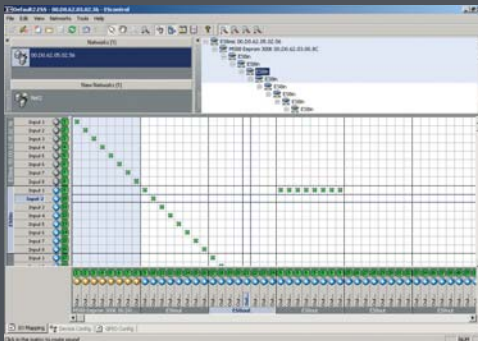

Configuration		
Bus/Format	PCI master mode	PCI master mode
Digital Signal Processor	8240 Power PC at 250 MHz	-
Inputs/outputs		
Analog mono inputs	4 balanced, line/mic inputs with phantom power 4 balanced, line inputs	-
Analog inputs 1 to 4		
Impedance	>8 kΩ	-
Analog gain adjustment	0.5 dB steps	-
Max input level	+22 dBu	-
Analog inputs 5 to 8-		
No analog gain adjustment	Switchable during installation	-
Input level to ensure 0 dBFS	between +10 dBu and +22 dBu	-
Analog mono outputs	8 balanced line outputs	-
Impedance	<100 Ω	-
Maximum level	+22 dBu	-
Analog input/output gain	0.5 dB steps	-
Connectivity		
Analog audio	8 male XLR3 and 8 female XLR3	-
EtherSound	2 female RJ45 compatible (connections "IN"/"OUT")	2 female RJ45 compatible (connections "In"/"Out")
Audio specifications		
Sampling frequency	From 7 - 50 kHz in 100 Hz steps	48 kHz or 44.1 kHz (Primary Master: 48 kHz only)
Audio processing	32 bit floating point	-
A/D and D/A converter resolution	24 bits	-
Frequency response at 48 kHz (record + play)	20 Hz – 20 kHz: ± 0.2 dB	-
Signal-to-noise ratio (unweighted)	>93 dB (line)	-
Distortion and noise (THD+N) at 1 kHz (-1 dBfs with Fs=48 kHz)	<-88 dB (0.004%)	-
Phase difference between channels: 20 Hz/20 kHz	0.5°/2°	-
Crosstalk at 1 kHz (-1 dBfs with Fs=48 kHz)	<-105 dB	-
Software environments		
Audio management	Wave or Digigram management based on np SDK, Vconsole Builder, VConsole Designer Kit	Low-latency WDM DirectSound and ASIO
OS supported	Windows 2000, XP 128 MB RAM	Windows XP, 2003 Server (32-bit version) 128 MB RAM
DSP software features		
Default	PCM, scrub, time-stretching, mixing, routing, digital levels, phase inversion, mute, panning, balance, parametric equalization, compression/expander, noise gate	-
Optional	MPEG layer I, II encoding/decoding and mp3 decoding; Sample Rate Conversion; Delay	-
Synchronization		
Clock source	-	If 'Primary Master' in an EtherSound network: Internal or Word Clock input Network (44.1 or 48kHz), internal (48kHz) or Word Clock (44.1 or 48Khz)

* Warning : miXart 8 ES is not RoHS compliant

EScontrol Software

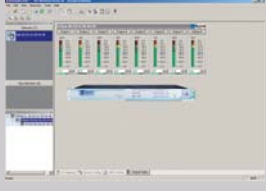
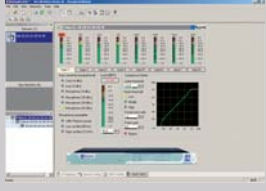

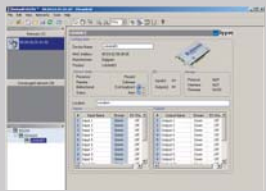
- Client/server application for management of audio routing and additional functions of Digigram's EtherSound range of products
- Delivered free of charge with EtherSound ES8in, ES8mic, ES881v2, ES1241v2, ES16161v2, LX6464ES and miXart 8 ES
- Single point of control for the entire network. Management of multiple EtherSound networks in the same window.
- Server application
 - Connected to the controlled EtherSound network(s) via non-dedicated Ethernet.
- Client application
 - Multi-client application
 - Connection to the server from anywhere via TCP/IP network (Internet). Possibility for remote system management and diagnosis.
 - Straightforward matrix interface
 - Example of additional controls: ES8mic mic preamps: gain, phantom power, low and high pass filters, compressor/limiter parameters
 - GPIO control
 - Automated network discovery accelerates system set-up
 - Saves network-wide EtherSound configurations for instant reload
- OS supported: Windows 2000, XP, Vista.
- Stand-alone mode for network design off-line.

Product	Remote controllable functions via EScontrol
ES8in	 <ul style="list-style-type: none"> • I/O routing • Input VUmeters • GPIO configuration
ES8out	 <ul style="list-style-type: none"> • I/O routing • Output VUmeters • Output gain • GPIO configuration
ES8mic ES8micCL ES8micWM	 <ul style="list-style-type: none"> • I/O routing • Input VUmeters • Input sensitivity • Input gain • Phantom power on/off • Low and high cut filters on/off • ES8micCL only: compressor/limiter functions (limiter threshold, noise threshold, compression ratio, output gain, bypass on/off) • GPIO configuration
ES220/ ES220-L	 <ul style="list-style-type: none"> • Input and output VUmeters • Output gain • GPIO configuration
miXart 8 ES	 <ul style="list-style-type: none"> • I/O routing
LX6464ES	 <ul style="list-style-type: none"> • I/O routing
ES881v2 ES1241v2 ES16161v2	 <ul style="list-style-type: none"> • I/O routing • Input and output VUmeters • Sample Rate Converters on/off • Clock configuration (44.1 or 48 kHz, AES in 1, Word clock) • GPIO configuration

About EtherSound ES100 ethernet networking professional audio



EtherSound is an elegant, simple, and open digital audio network standard with extremely low latency that is fully compliant with the IEEE's 802.3x Ethernet specification.

- **Channel count (at 44.1/48kHz)**
 - Per 100 Mbps cable: up to 64 channels in each direction
 - Per system: Total channel count may exceed 128 by "overwriting" existing channels in parts of the network.
 - All channels are independent from one another.
 - In bi-directional daisy-chains all channels are available to all nodes. In star architectures or uni-directional daisy-chains, all channels are available to all nodes "downstream" of the input.
- **Sampling frequency:** 44.1 kHz or 48 kHz or multipliers/divisors (88.2, 96, 24 kHz, etc.)
- **Audio format:** 24-bit PCM
- **Audio clock:** All devices are synchronized from the clock

reference of a master device on the network. Phase can be recovered using a distributed Word Clock source.

- **Bandwidth requirements: dedicated 100 Mbps Ethernet network. Operational in VLANs on Gigabit networks.**
- **Latency:**
 - Network latency (SSI in to SSI out): 125 micro-seconds (six samples at 48 kHz)
 - Independent from the number of channels
 - Additional latency per device in a daisy-chain: 1.4 microseconds
 - Additional latency per switch: 5 – 20 microseconds
 - Overall latency, including A/D and D/A conversion: 1.5-2 milliseconds
 - EtherSound is deterministic with stable latency: delay and phase between any two nodes can be calculated.
- **Ethernet standard compliance**
 - Fully IEEE 802.3x compliant.
 - Operational with standard Ethernet network layer 1 & 2 components (cables, fiber optics, switches, media converters, etc.)

• **Control and monitoring data over the same cable**

- Network remote control through embedded control data
 - Standard control software with multi vendor support: EScontrol
 - Control application generator with multi vendor support via strategic partnership with Stardraw.com
 - ES command port for microcontroller based control system
- ### • **Network architectures:**
- Daisy-chain / Redundant ring
 - Star through Ethernet switches
 - Combination of daisy-chain and star
- ### • **Inter-operability**
- EtherSound enabled products are available from a number of leading audio equipment manufacturers for installed sound and pro audio applications.
 - Regardless of the product's manufacturer, all products can operate as a unified system on the same network, exchanging audio and control signals.



Digigram (www.digigram.com) digital audio solutions are key to the success of public address and pro sound installations, as well as broadcast and media production companies worldwide. We develop innovative networked audio devices, computer sound cards, and audio management software.

Digigram Powered solutions are installed in thousands of radio and television stations; corporate and commercial sound installations; and audio recording and video post-production facilities around the globe.

Customers are served from three regional business units: Digigram SA (Digigram Headquarters, Montbonnot, France), Digigram Inc. (Arlington, VA USA), and Digigram Asia (Singapore). Digigram is publicly traded on the Paris stock exchange (Code ISIN: FR 00000 35784).

Digigram SA

(Serving Europe, Africa, Middle East, Latin America)

Parc de Pré Milliet
38330 Montbonnot-FRANCE
Tel: +33 (0)4 76 52 55 01
Fax: +33 (0)4 76 52 53 07
E-mail: sales@digigram.com

Digigram Inc.

(Serving North America)

2101 Wilson Boulevard, Suite 1004,
Arlington, VA 22201-USA
Tel: +1 703 875 9100
Fax: +1 703 875 9161
E-mail: input@digigram.com

Digigram Asia Pte Ltd.

(Serving Asia and Australia/Oceania)

350 Orchard Road
#19-07 Shaw House Singapore
238868-SINGAPORE
Tel: +65 6291 2234 - Fax: +65 6291 3433
E-mail: info_asia@digigram.com

www.digigram.com